

Allusion Series

SNACK AND DRINK MACHINES



The Allusion series of vending machines are the latest in vending technology to hit the market. The Allusion machines are convenient for both customers and operators with the range of machines tailored to meet different operator and customer needs.

This ranges from the high capacity A9 with a product capacity of over 315 units, the A4 with a unique high volume can vending system and the A6 with the traditional snack and drink setup.

The Allusion vending machine range can be easily operated and maintained with their user friendly interface and design, making them the most reliable and efficient machines on the market.

The machines offer true versatility with many features including their flexible tray system. This allows products of many different dimensions and sizes to be vended from the machines.

The Allusion series consists of some of the finest vending machines on the market and are the right choice for a true vending professional.

Allusion Series **SNACK AND DRINK MACHINES**

Features:

- Vending Versatility** The adaptable shelving system allows products of many different shapes and sizes to be vended with ease.
- User Friendly Design** Navigating the electronics of the machine is made easy with a large LED display and text based menu system.
- Self Diagnosis** Day-to-day maintenance can be quick and efficient with the machines automatic self diagnosis capabilities.
- Fail Safe Delivery System** This stable and reliable system ensures that purchased products drop into the delivery box. If the purchased product does not drop the customer will receive a full refund.
- Promotional Functionality** The range comes with inbuilt promotional settings including the 'winner mode'.
- Refrigeration Variability** The machine temperature can be varied and go as low as 3°C. This allows the machine to vend refreshing beverages, snacks and fresh food.
- High Quality Display** The gas filled double glazed toughened glass provides impact resistance and viewing free from condensation.
- Adjustable Feet** The fully adjustable feet allow the machines to be placed on uneven surfaces.
- Accessories** The machines have the option to come with coin mechanisms and note readers.



Allusion - A6 Shelf Versatile Configuration

	Selection	Capacity	Total
Top Shelf	3 Chip	Chip (3x7) = 21	= 21
2nd Shelf	2 Chip & 1 Cookie	Chip (2x7) = 14 & Cookie (1x15) = 15	= 29
3rd Shelf	6 Chocolate	Chocolate (3x15) + (3x10)	= 75
4th Shelf	6 Bottle or Large cans	Large Bottles (4x4) & Bottles (2x5)	= 26
5th Shelf	4 Cans & 2 Energy Drink Cans	Energy (2x6) & Cans (4x5)	= 32
Bottom Shelf	6 Cans	Cans (6x5)	= 30

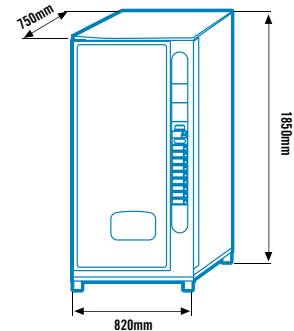

Allusion - A9 Shelf Versatile Configuration

	Selection	Capacity	Total
Top Shelf	3 Chip & 3 Chocolate	Chip (3x7) = 21 & Chocolate (2x15) = 30	= 51
2nd Shelf	3 Chip & 3 Chocolate	Chip (3x7) = 21 & Chocolate (2x15) = 30	= 51
3rd Shelf	3 Cookie & 3 Chocolate	Cookie (3x15) = 45 & Chocolate (3x15) = 45	= 90
4th Shelf	9 Bottle or Large cans	Bottles (6x5) & Large Bottles (3x4)	= 42
5th Shelf	6 Cans & 3 Energy Cans	Cans (6x5) = 30 & Energy Cans (3x6) = 18	= 48
Bottom Shelf	9 Cans	Cans (9x5) = 45	= 45

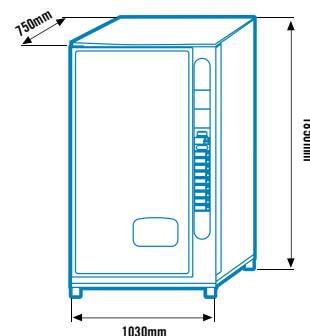

Allusion - A4 Shelf Versatile Configuration

	Selection	Capacity	Total
Top Shelf	3 Chip	Chip (3x7) = 21	= 21
2nd Shelf	3 Chocolate & 1 Cookie	Cookie (1x15) = 15 & Chocolate (3x15) = 45	= 51
3rd Shelf	6 Bottle	Bottle (3x5) & Large Bottles (3x4)	= 32
4th Shelf	4 Cans & 2 Energy Cans	Energy Cans (2x6) & Cans (4x5)	= 32
Can Dispenser	3 Cans	Cans (3x25) = 75	= 75

